

# 8600

Series Telescopic Crane



## ► 8600 Series Telescopic Crane

Let our telescopic cranes take on the heavy lifting. The IMT 8600 Series telescopic crane has a maximum lifting capacity of 8600 lb (3900.9 kg) and a horizontal boom reach of 30' (9.1 m) — the longest in the industry. Featuring the Penta Boom™ design, this crane is built for strength and control, and when combined with an IMT Dominator® mechanics truck, creates the ultimate service and maintenance truck.

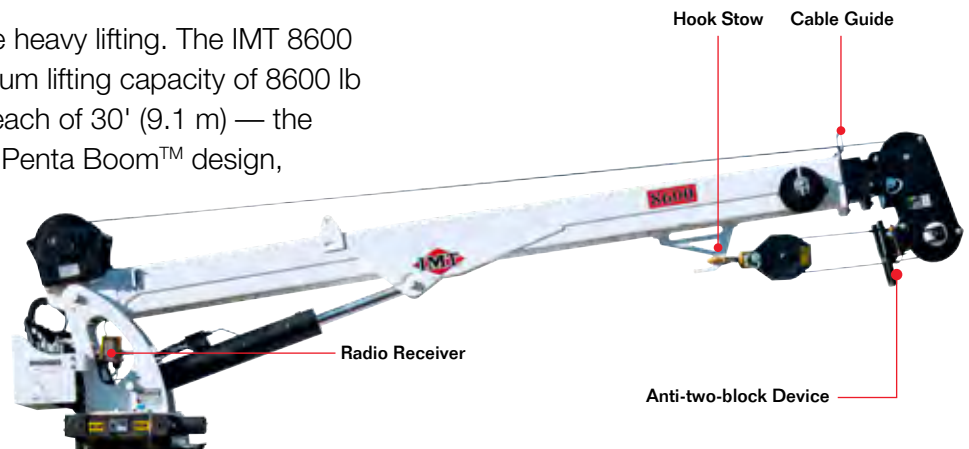

### Standard Features

- 30' (9.1 m) of boom reach
- Fully proportional “pistol grip” radio remote control
- Flip sheave boom tip
- Boom angle -10° to +80° (-0.2 to 1.4 rad)
- Increased capacity
- Patented hook stow
- Patented anti-two-block device
- Radio remote control receiver

### Options

- 22' (6.7 m)
- Boom tip lights

### Body Sizes

- Dominator II



### Radio Remote Control

Our pistol grip handle is ergonomic while increasing comfort and decreasing hand fatigue and is available with joystick or toggle switch controls.



### Radio Remote Control Receiver

To simplify troubleshooting and increase productivity, our radio remote control receiver provides an LED readout detailing error codes. It also uses programmable logic for precise control of individual functions.



### Flip Sheave

Our unique flip sheave allows operators to work in tighter areas by reducing the boom tip profile height by 8" (20.3 cm).

### Minimum Chassis Specifications

Chassis Style	Conventional Cab
Front Axle Rating (GAWR)	7000 lb (3175 kg)
Rear Axle Rating (GAWR)	15,000 lb (6804 kg)
Wheelbase	154" (391 cm)
Cab-to-Axle	84" (213 cm)
Resistance to Bending Moment Minimum	1,200,000 in-lb (13,825 kg-m)
Frame Section Modulus	14.2 cu in (232.7 cm <sup>3</sup> )
Gross Vehicle Weight Rating	22,000 lb (9979 kg)

In addition to these specifications, heavy-duty electrical and cooling systems are required. It is recommended that the vehicle be equipped with an engine tachometer, auxiliary brake lock, and power steering.



### Penta Boom Design

Different material thickness to address structural requirements, while controlling the weight of the crane.

## 8600 Series Specifications

### 22' Boom

Crane Rating*	52,000 ft-lb (7.3 tm)
Max. Capacity	8600 lb (3900.9 kg)
Max. Horizontal Reach (with flip sheave up)	22' 6" (6.9 m)
Max. Horizontal Reach (with flip sheave down)	21' 8" (6.6 m)
Max. Capacity @ Max. Reach	2140 lb (970 kg)
Fully Retracted	11' 11" (3.6 m)
Hydraulic Extensions	59.7" (151.6 cm) 57.2" (145.3 cm)
Lifting Height (with flip sheave down)	23' 10" (7.3 m)
Crane Weight	1825 lb (827.8 kg)
Crane Storage Height	40.6" (103.1 cm)
Center of Gravity	Horizontal from CL of rotation 42" (106.7 cm) Vertical from bottom of crane base 19.6" (49.8 cm)
Required Mounting Space for Crane Base	20" x 21" (50.8 x 53.3 cm)
Optimum Pump Capacity	10 – 12 gpm (37.9 – 45.4 L/min)
Tie-Down Bolt Pattern	14.75" x 14.75" (37.5 x 37.5 cm)
Rotational Torque	9000 ft-lb (1.3 tm)
Main Boom Elevation Speed	12 sec
Extension Boom Extend Speed	33 sec

\*Crane rating (ft-lb) is the rated load (lb) x the respective distance (ft) from centerline of rotation with all extensions retracted and lower boom in horizontal position.

### 22' Load Chart

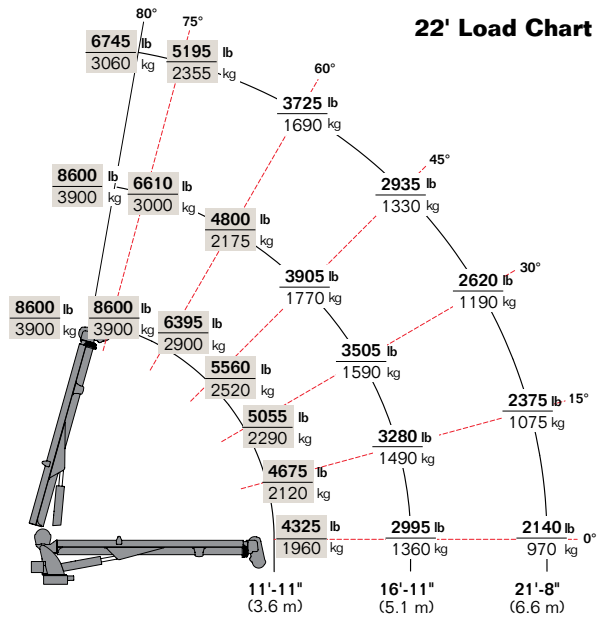

- Maximum one-part line weight is 4300 lb (1950 kg)
- The weight of load-handling devices is part of the load lifted and must be deducted from the rated capacity

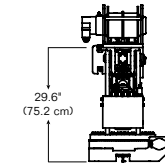
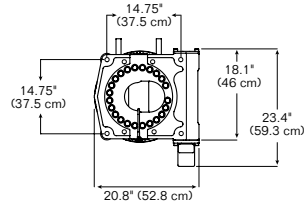
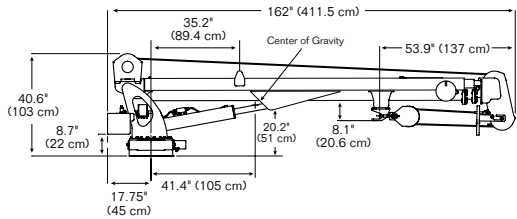

## 8600 Series Specifications

### 30' Boom

Crane Rating*	60,000 ft-lb (8.4 tm)
Max. Capacity	8600 lb (3900.9 kg)
Max. Horizontal Reach (with flip sheave up)	30' 10" (9.3 m)
Max. Horizontal Reach (with flip sheave down)	30' (9.1 m)
Max. Capacity @ Max. Reach	1575 lb (714.4 kg)
Fully Retracted	12' 11" (3.9 m)
Hydraulic Extensions	102" x 2 (259 cm x 2)
Lifting Height (with flip sheave down)	32' 1" (9.8 m)
Crane Weight	2410 lb (1093.2 kg)
Crane Storage Height	40.6" (103.1 cm)
Center of Gravity	Horizontal from CL of rotation 49.9" (126.8 cm) Vertical from bottom of crane base 22.2" (56.4 cm)
Required Mounting Space for Crane Base	20" x 21" (50.8 x 53.3 cm)
Optimum Pump Capacity	10 – 12 gpm (37.9 – 45.4 L/min)
Tie-Down Bolt Pattern	14.75" x 14.75" (37.5 x 37.5 cm)
Rotational Torque	9000 ft-lb (1.3 tm)
Main Boom Elevation Speed	12 sec
Extension Boom Extend Speed	33 sec

\*Crane rating (ft-lb) is the rated load (lb) x the respective distance (ft) from centerline of rotation with all extensions retracted and lower boom in horizontal position.

### 30' Load Chart

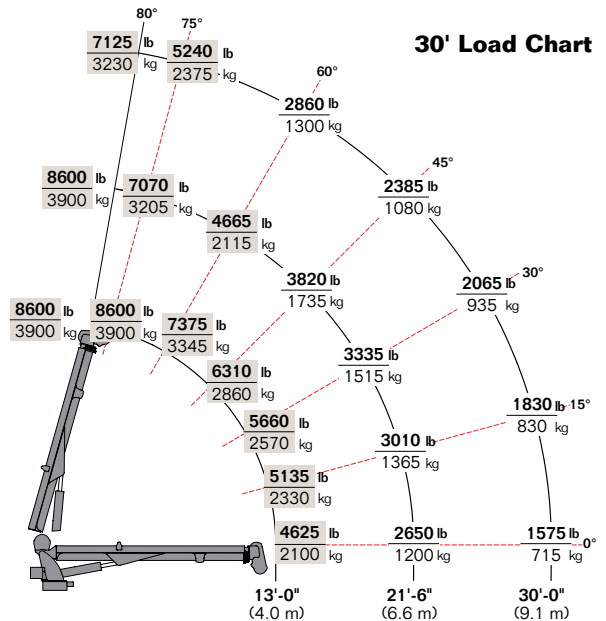

- Maximum one-part line weight is 4300 lb (1950 kg)
- The weight of load-handling devices is part of the load lifted and must be deducted from the rated capacity

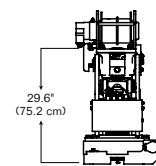
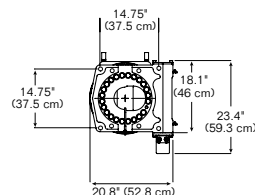
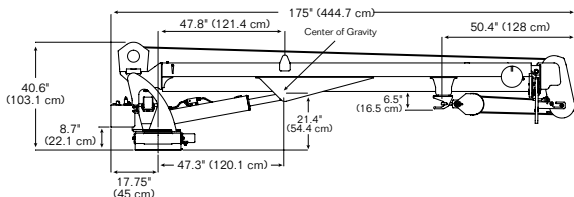

## Power Source

- Power provided by integral-mounted hydraulic pump and PTO
- Min. requirement is 23.5 hp (17.5 kW) based on 10 gpm at 3000 psi (37.9 L/min at 206.8 bar)
- Other standard power sources can be utilized

## Cylinder Holding Valves

- All cylinders equipped with integral-mounted counterbalance valves
- Prevent sudden cylinder collapse in case of component failure

## Rotation System

- Consists of a worm gear and turntable gear bearing
- Powered by a high-torque hydraulic motor
- Standard rotation is 400° (6.98 rad)
- Speed rotation is 30 seconds

## Excessive Load Limit System (ELLS)

- Pressure transducer used to sense overload
- When overloaded, the following functions are stopped: boom down, extension out, and winch up

## Planetary Winch

- Capacity of 4400 lb (1996 kg) powered by high-torque hydraulic motor
- Single line operating speed of 60 fpm (18.2 m/min) under no-load conditions
- Maximum two-part line capacity of 8600 lb (3900 kg)
- Equipped with 85' (25.9 m) of 3/8" (9.5 mm) of 6 x 25 FW PRF LRL IWRC XIPS wire rope
- Anti-two-block prevents the snatch block assembly from coming in contact with boom tip
- Speed of winch is 60 fpm (0.3 m/sec)
- Meets ANSI B30.5 standards

## Hydraulic System

- Open-centered, full pressure system
- System requires 10 gpm (37.9 L/min) optimum oil flow at 3000 psi (206.8 bar)
- Fully proportional control valve with "pistol grip" radio remote control system
- Includes radio elimination cable, hydraulic oil reservoir, and suction and return line filters



### Nothing Says Commitment Like The Diamond.™

IMT has been meeting the needs of our customers for over 50 years, and none of it would have been possible without a distributor network that's second to none. IMT distributors offer fast, knowledgeable service and the ability to help customers find the right product for every application. When you're looking for reliable equipment and dependable service, remember IMT.



An Oshkosh Corporation Company

### Iowa Mold Tooling Co., Inc.

500 Highway 18 West  
Garner, Iowa 50438  
800-247-5958 • [www.imt.com](http://www.imt.com)

IMT reserves the right to make changes in engineering, design, and specifications; add improvements; or discontinue manufacturing at any time without notice or obligation. IMT, IMT logo, Dominator, Penta Boom and NOTHING SAYS COMMITMENT LIKE THE DIAMOND are registered trademarks or trademarks of Iowa Mold Tooling Co., Inc., Garner, IA, USA.  
© 2015 Iowa Mold Tooling Co., Inc. All Rights Reserved.

06/15